

SECTION A-A
SCALE 16:1

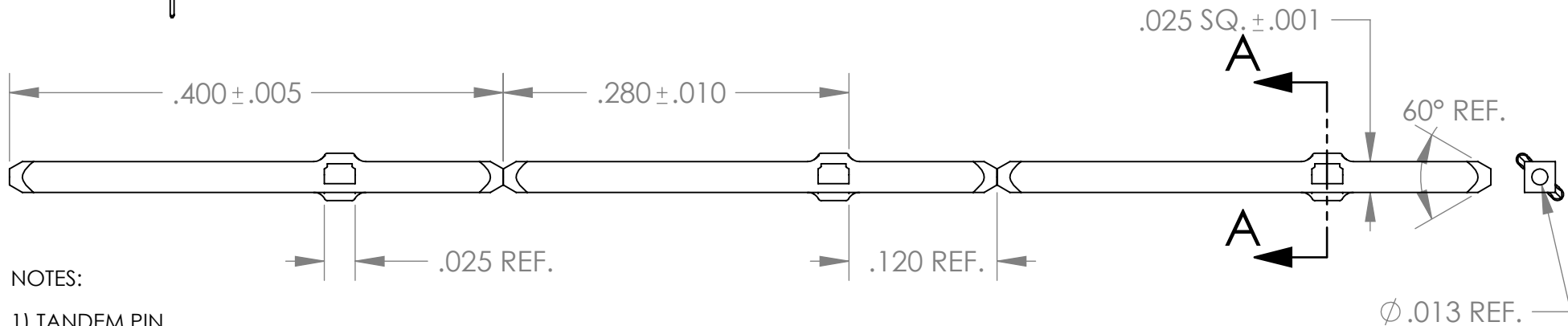

NOTES:

- 1) TANDEM PIN
- 2) PIN TIPS ARE PARABOLA REVOLVED
- 3) WIND SHORT END FIRST ONTO REEL, END USER TO UNWIND LONG END FIRST
- 4) WIND 50,000 PER REEL
- 5) MEASURE EARS FROM TANGENT POINT
- 6) RECOMMENDED HOLE SIZE:
 DRILL - $\phi .033" \pm .001"$
 COPPER 1OZ PLATE - $\phi .029" \pm .002"$
 TIN PLATE - $\phi .028" \pm .002"$
 STANDOFF HOLE - $\phi .040" \pm .004"$

CONTROLLED DOCUMENT
MANUFACTURING / FINISH PRINT

UNLESS OTHERWISE SPECIFIED:		NAME	DATE
DIMENSIONS ARE IN INCHES TOLERANCES: FRACTIONAL ± ANGULAR: MACH ± BEND ± TWO PLACE DECIMAL ± THREE PLACE DECIMAL ±	ORIGINAL BY	J.B.	1/5/07
	UPDATED BY	T.P.	8/6/10
	ENG APPR.		
	MFG APPR.		
INTERPRET GEOMETRIC TOLERANCING PER:	Q.A.		
MATERIAL CDA 260	COMMENTS:		
FINISH			
DO NOT SCALE DRAWING			

www.BeadElectronics.com

TITLE:

W025-480AC

SIZE	DWG. NO.	REV
A		

SCALE: 1:1 WEIGHT: SHEET 1 OF 1



PROPRIETARY AND CONFIDENTIAL
 THE INFORMATION CONTAINED IN THIS DRAWING IS THE SOLE PROPERTY OF BEAD INDUSTRIES. ANY REPRODUCTION IN PART OR AS A WHOLE WITHOUT THE WRITTEN PERMISSION OF BEAD INDUSTRIES IS PROHIBITED.