

SECTION A-A  
SCALE 16:1

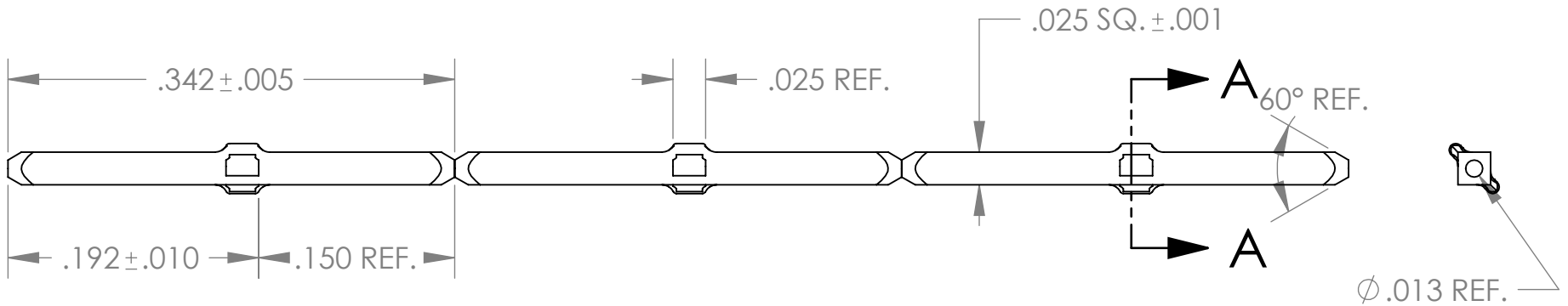

NOTES:

- 1) TANDEM PIN
- 2) PIN TIPS ARE PARABOLA REVOLVED
- 3) WIND SHORT END FIRST ONTO REEL,  
END USER TO UNWIND LONG END FIRST
- 4) MEASURE EARS FROM TANGENT POINT
- 5) WIND 50,000 PER REEL

CONTROLLED DOCUMENT  
MANUFACTURING / FINISH PRINT

- 6) RECOMMENDED HOLE SIZE:  
DRILL -  $\phi .033 \pm .001$ "  
COPPER 1oz PLATE -  $\phi .029 \pm .002$ "  
TIN PLATE -  $\phi .028 \pm .002$ "  
STANDOFF HOLE -  $\phi .040 \pm .004$ "

UNLESS OTHERWISE SPECIFIED:		NAME	DATE
DIMENSIONS ARE IN INCHES TOLERANCES: FRACTIONAL ± ANGULAR: MACH ± BEND ± TWO PLACE DECIMAL ± THREE PLACE DECIMAL ±	ORIGINAL BY	J.B.	1/8/07
	UPDATED BY	T.P.	8/9/10
	ENG APPR.		
	MFG APPR.		
INTERPRET GEOMETRIC TOLERANCING PER:	Q.A.		
MATERIAL C197	COMMENTS:		
FINISH			
DO NOT SCALE DRAWING			

www.BeadElectronics.com

TITLE:

**W025-486EAC**

SIZE <b>A</b>	DWG. NO.	REV
SCALE: 1:1	WEIGHT:	SHEET 1 OF 1



**PROPRIETARY AND CONFIDENTIAL**  
THE INFORMATION CONTAINED IN THIS DRAWING IS THE SOLE PROPERTY OF BEAD INDUSTRIES. ANY REPRODUCTION IN PART OR AS A WHOLE WITHOUT THE WRITTEN PERMISSION OF BEAD INDUSTRIES IS PROHIBITED.