

SECTION A-A  
SCALE 16 : 1

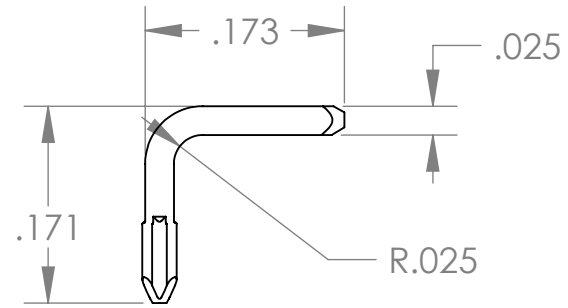

AFTER INSERTION

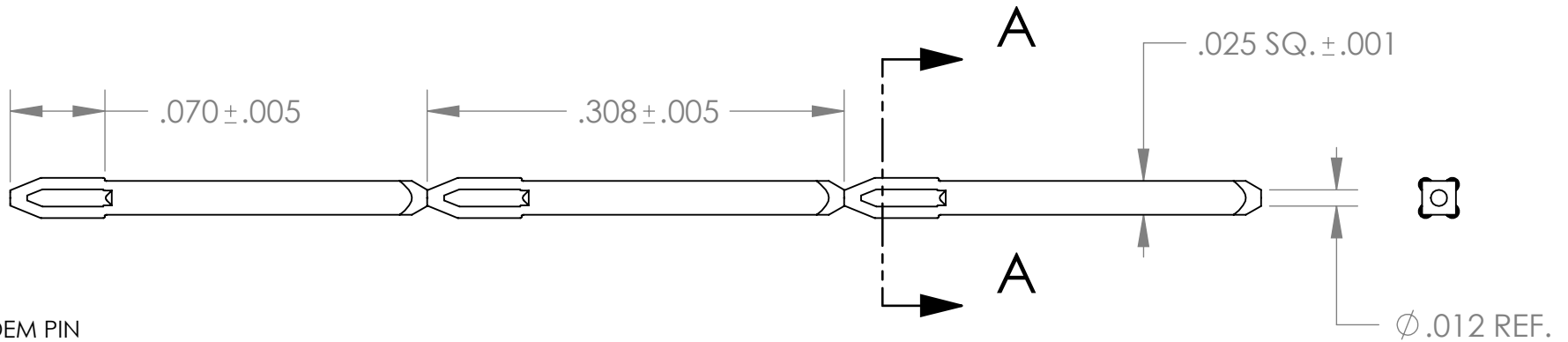

NOTES:

- 1) TANDEM PIN
- 2) PIN TIPS ARE PARABOLA REVOLVED
- 3) WIND LONG END FIRST ONTO REEL,  
END USER TO UNWIND STAR END FIRST
- 4) MEASURE STAR FROM TANGENT POINT
- 5) WIND 50,000 PER REEL

CONTROLLED DOCUMENT  
MANUFACTURING / FINISH PRINT

UNLESS OTHERWISE SPECIFIED:  DIMENSIONS ARE IN INCHES TOLERANCES: FRACTIONAL ± ANGULAR: MACH ± BEND ± TWO PLACE DECIMAL ± THREE PLACE DECIMAL ±	ORIGINAL BY	NAME	DATE	<a href="http://www.BeadElectronics.com">www.BeadElectronics.com</a>  TITLE:  <h1>W025-587AC</h1>  SIZE DWG. NO. REV <b>A</b>	
	UPDATED BY	J.B.	8/21/08		
	ENG APPR.	T.P.	8/10/10		
	MFG APPR.				
	Q.A.				
INTERPRET GEOMETRIC TOLERANCING PER:	COMMENTS:			SCALE: 1:1 WEIGHT: SHEET 1 OF 1	
MATERIAL	C 194				
FINISH					
DO NOT SCALE DRAWING					



**PROPRIETARY AND CONFIDENTIAL**  
 THE INFORMATION CONTAINED IN THIS DRAWING IS THE SOLE PROPERTY OF BEAD INDUSTRIES. ANY REPRODUCTION IN PART OR AS A WHOLE WITHOUT THE WRITTEN PERMISSION OF BEAD INDUSTRIES IS PROHIBITED.